



**Construction**

Horizontal multi-stage close coupled pumps in **chrome-nickel stainless steel**.

Compact and robust construction, without protruding flange and with single-piece lantern bracket and base.

Single-piece barrel casing, with front suction port above pumps axis and radial delivery at top.

Filling and draining plugs on the middle of the pump, accessible from any side (like the terminal box).

**Applications**

For water supply.

For clean liquids, without abrasives, which are non-aggressive for stainless steel (with suitable seal materials, on request).

Universal pump, for domestic use, for civil and industrial applications, for garden use and irrigation.

**Operating conditions**

Liquid temperature from - 15 °C to + 110 °C.

Ambient temperature up to 40 °C.

Maximum permissible pressure in the pump casing: 8 bar.

Continuous duty.

**Motor**

2-pole induction motor, 50 Hz (n = 2800 rpm).

**MXH:** three-phase 230/400 V ± 10%.

**MXHM:** single-phase 230 V ± 10%, with thermal protector.

Capacitor inside the terminal box.

Insulation class F.

Protection IP 54.

Constructed in accordance with: IEC 60034;

IEC 60038;

IEC 60335-1, EN 60335-1;

IEC 60335-2-41, EN 60335-2-41;

**Materials**

Component	Material
Pump casing	Chrome-nickel steel 1.4301 EN 10088 (AISI 304)
Stage casing	Chrome-nickel steel 1.4301 EN 10088 (AISI 304)
Wear ring	PTFE
Impeller	Chrome-nickel steel 1.4301 EN 10088 (AISI 304)
Casing cover	Chrome-nickel steel 1.4301 EN 10088 (AISI 304)
Spacer sleeve	Chrome-nickel steel 1.4301 EN 10088 (AISI 304)
Pump shaft	Chrome-nickel steel 1.4305 EN 10088 (AISI 303)
Plug	Chrome-nickel steel 1.4305 EN 10088 (AISI 303)
Mechanical seal with seat according to ISO 3069	Ceramic alumina, carbon, EPDM (Other materials on request)

**Special features on request**

- Other voltages.
- Frequency 60 Hz (as per 60 Hz data sheet).
- Protection IP 55.
- Special mechanical seal
- Pump casing seal rings in FPM.
- Higher or lower liquid or ambient temperatures.

**Coverage chart n ≈ 2800 rpm**

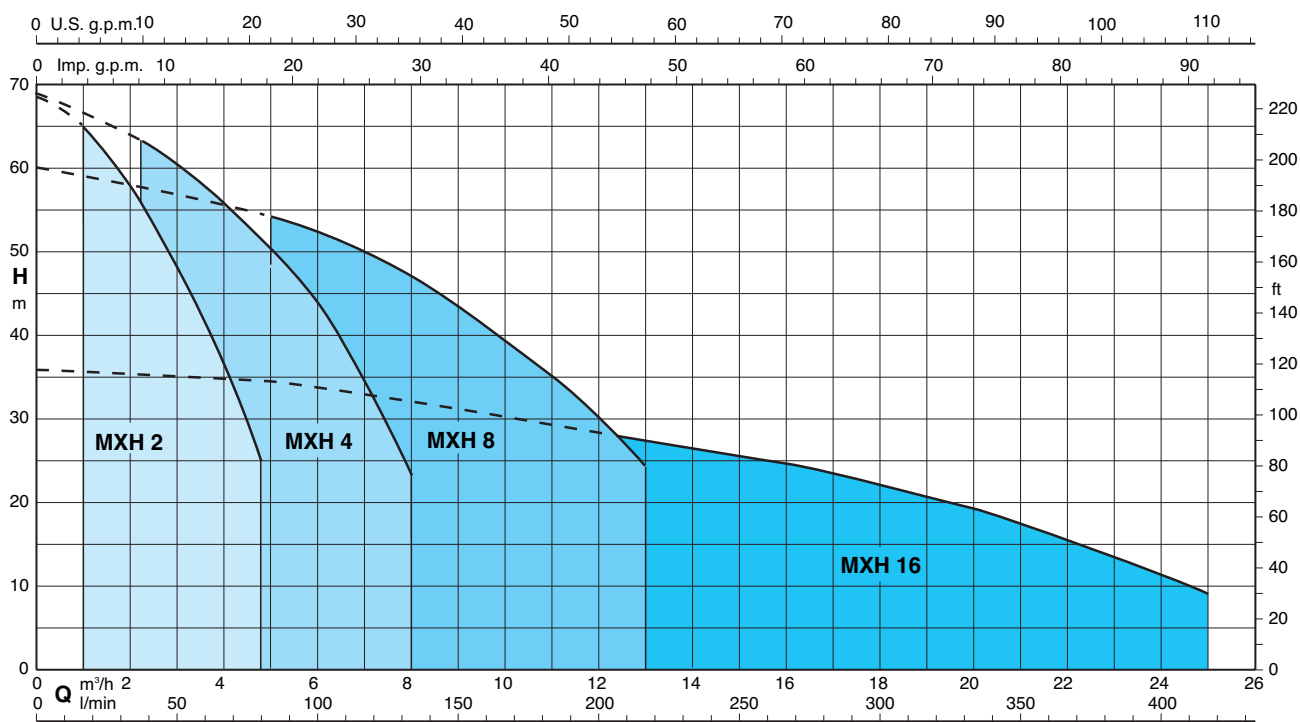

### Performance n ≈ 2800 rpm

3 ~	230 V		400 V		1 ~	230 V		P <sub>1</sub>	P <sub>2</sub>		Q										
	A	A	A	A		kW	kW		HP	m <sup>3</sup> /h		l/min	0	1	1,5	2	2,5	3	3,5	4	4,25
MXH 202E	1,7	1	MXHM 202E	2,3	0,5	0,33	0,45	H m	22	20,5	19,4	18	16,4	14,2	12	9,9	8,7	5,5			
MXH 203E	2,4	1,4	MXHM 203E	3	0,65	0,45	0,6			33	31	29	27	24,5	21,7	18,6	15,5	13,8	9		
MXH 204E	2,8	1,6	MXHM 204E	4,2	0,9	0,55	0,75			45	42,5	40,4	37,5	34,5	30,8	26,7	22,4	20,1	14,8		
MXH 205E	3,5	2	MXHM 205E	5,4	1,2	0,75	1			57	53,5	50,5	47,5	43,5	39	34	28,5	25,8	19		
MXH 206E	4,7	2,7	MXHM 206	7,4	1,5	1,1	1,5			68,5	65	61,5	58	53,5	48	43	36,5	33,5	25		

3 ~	230 V		400 V		1 ~	230 V		P <sub>1</sub>	P <sub>2</sub>		Q										
	A	A	A	A		kW	kW		HP	m <sup>3</sup> /h		l/min	0	2,25	3	3,5	4	4,5	5	6	7
MXH 402E	2,4	1,4	MXHM 402E	3	0,65	0,45	0,6	H m	22,5	20	19	18,5	17,5	16	15	12,5	9,5	6			
MXH 403E	2,8	1,6	MXHM 403E	4,2	0,9	0,55	0,75			33	30	29	27,5	26	24,5	23	19,5	15	9,5		
MXH 404E	3,5	2	MXHM 404E	5,4	1,2	0,75	1			44,5	40,5	38	36,5	35	33	31	26	20	12,5		
MXH 405E	4,7	2,7	MXHM 405	7,4	1,5	1,1	1,5			56,5	52	50	47,5	45,5	43	40	33,5	26	16,5		
MXH 406	6,4	3,7	MXHM 406	9,2	2	1,5	2			68,5	63	60	58	56	53,5	51	44	35	23		

3 ~	230 V		400 V		1 ~	230 V		P <sub>1</sub>	P <sub>2</sub>		Q										
	A	A	A	A		kW	kW		HP	m <sup>3</sup> /h		l/min	0	5	6	7	8	9	10	11	12
MXH 802E	3,5	2	MXHM 802E	5,4	1,2	0,75	1	H m	22,5	20,5	20	19	18	16,5	15	13	11	8,5			
MXH 803	5	2,9	MXHM 803	7,4	1,5	1,1	1,5			36	32	30,5	29	27,5	25,5	23	20	17	14		
MXH 804	6,4	3,7	MXHM 804	9,2	2	1,5	2			48	42,5	41	39	37	34,5	32	28	24	19,5		
MXH 805	7,5	4,3								60	54	52	49,5	47	43,5	39,5	35	29,5	24		

3 ~	230 V		400 V		P <sub>2</sub>	Q											
	A	A	kW	HP			m <sup>3</sup> /h	l/min	0	5	8	11	14	16	18	20	22
MXH 1602	6,4	3,7	1,5	2	H m	24	23	21,7	20,5	18,8	17,5	15,8	14	11,5	6,5		
MXH 1603	7,5	4,3	1,8	2,5			36	34	31,8	29,5	26,8	24,8	22,4	19,2	15,3	8,8	

P<sub>1</sub> Max. power input. Test results with clean cold water, without gas content. + 0,5 m security margin on NPSH-value is necessary.  
P<sub>2</sub> Rated motor power output. Tolerances according to ISO 9906, annex A.

### Dimensions and weights

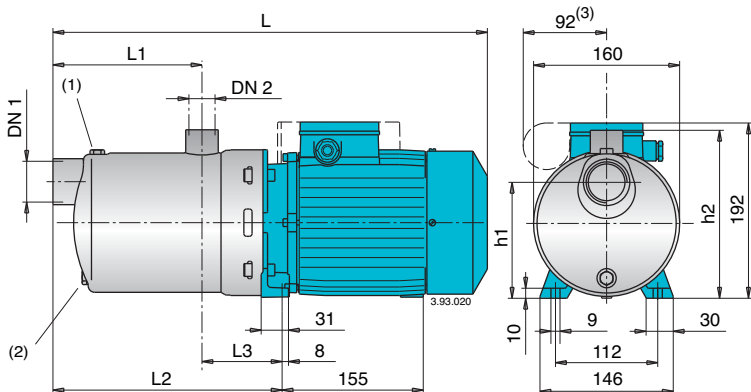
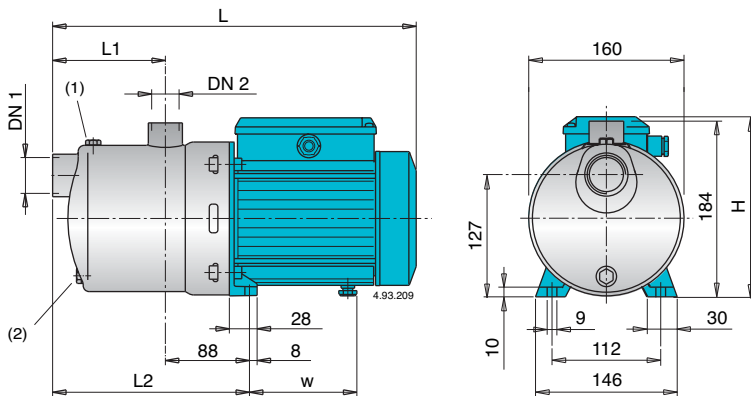

(1) Filling (2) Draining (3) MXHM

TYPE	DN1	DN2	mm						kg	
			L	L1	L2	H	w	MXH	MXHM	
MXH 202E - MXHM 202E	G 1 1/4	G 1	331	94	182	176	98,5	6,8	6,9	
MXH 203E - MXHM 203E	G 1 1/4	G 1	331	94	182	176	98,5	7,6	7,7	
MXH 204E - MXHM 204E	G 1 1/4	G 1	381	118	206	189	112	10	11	
MXH 205E - MXHM 205E	G 1 1/4	G 1	405	142	230	189	112	11,5	12,5	
MXH 206E	G 1 1/4	G 1	429	166	254	189	112	13,5	-	
MXH 402E - MXHM 402E	G 1 1/4	G 1	331	94	182	176	98,5	7,6	7,7	
MXH 403E - MXHM 403E	G 1 1/4	G 1	357	94	182	189	112	9,3	10,3	
MXH 404E - MXHM 404E	G 1 1/4	G 1	381	118	206	189	112	10,8	11,8	
MXH 405E	G 1 1/4	G 1	405	142	230	189	112	13	-	
MXH 802E - MXHM 802E	G 1 1/2	G 1	381	118	206	189	112	10,6	11,6	

TYPE	DN1	DN2	mm						kg	
			L	L1	L2	L3	h1	h2	MXH	MXHM
MXHM 206	G 1 1/4	G 1	488	166	254	88	127	184	-	18,6
MXHM 405	G 1 1/4	G 1	464	142	230	88	127	184	-	18
MXH 406 - MXHM 406	G 1 1/4	G 1	488	166	254	88	127	184	19,5	20,5
MXH 803 - MXHM 803	G 1 1/2	G 1	440	118	206	88	127	184	15,8	16,9
MXH 804 - MXHM 804	G 1 1/2	G 1	470	148	236	88	127	184	18,2	19,2
MXH 805	G 1 1/2	G 1	500	178	266	88	127	184	19	-
MXH 1602	G 2	G 1 1/2	464	128	230	101	117	187	18,2	-
MXH 1603	G 2	G 1 1/2	464	128	230	101	117	187	18,4	-

### Characteristic curves $n \approx 2800$ rpm

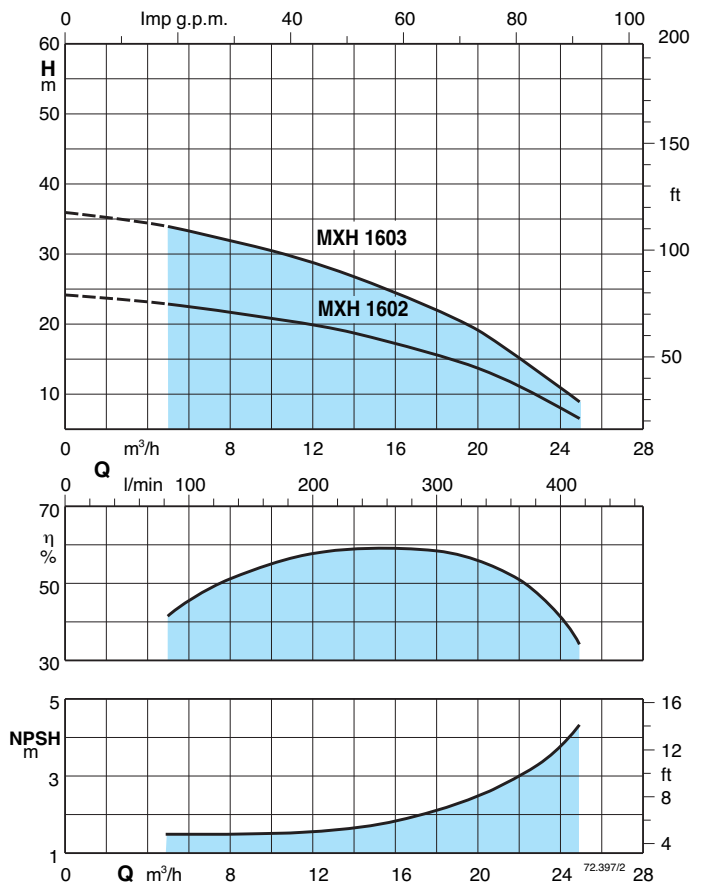
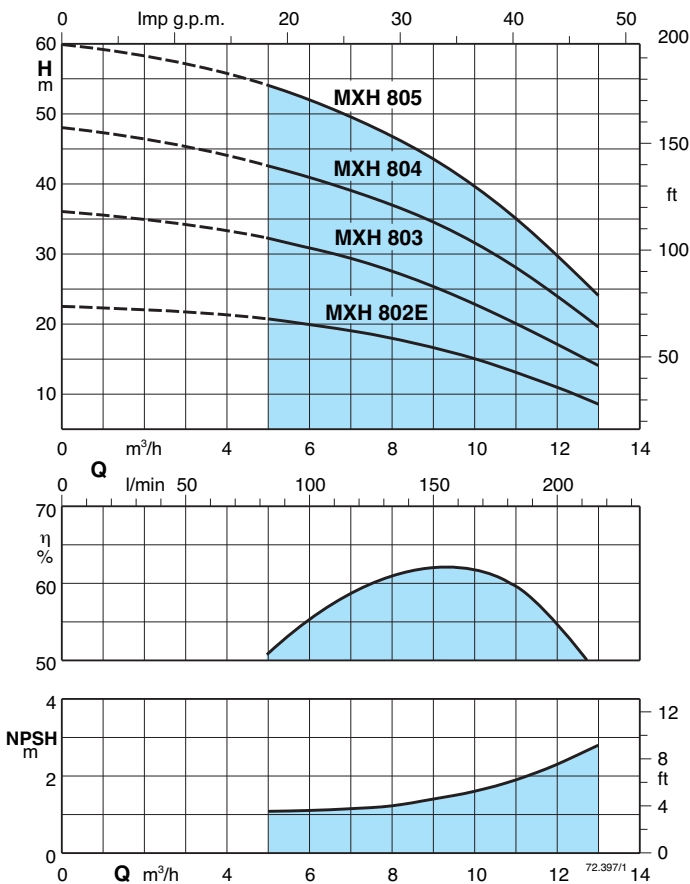
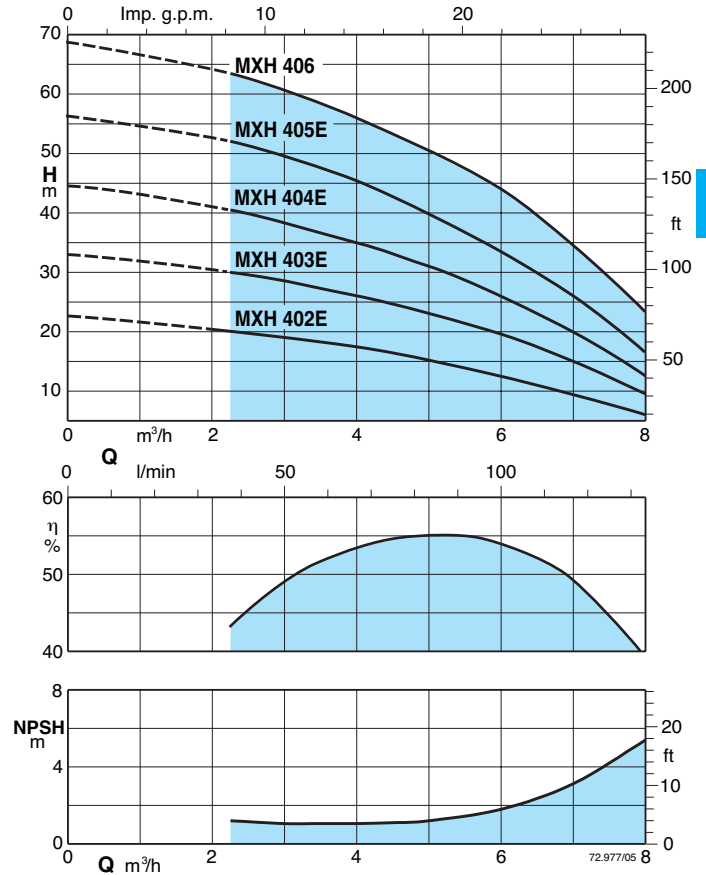
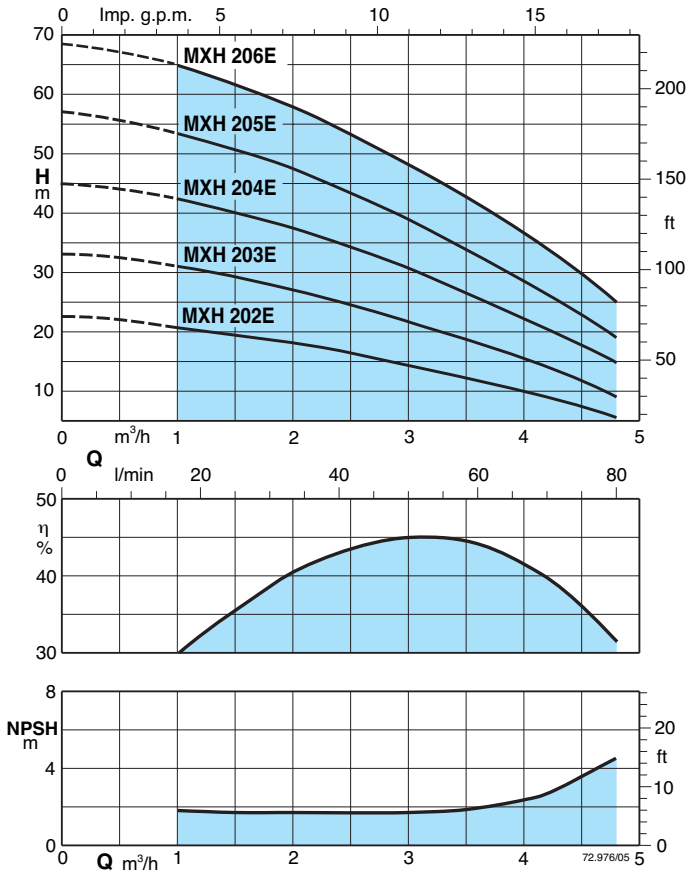

### Features

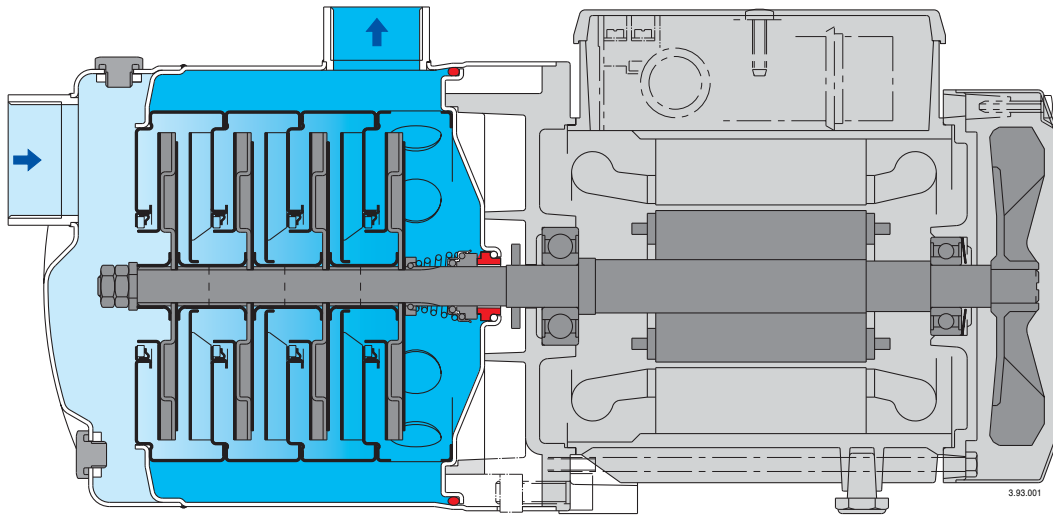

- Extra safety**  
against running dry, with the suction port above pump axis.
- Reliable**  
All hydraulic parts in contact with the pumped liquid are of stainless steel.  
For liquids from -15 °C to 110 °C.
- Robust**  
Single-piece, thick barrel casing.
- Compact**  
Single-piece lantern bracket and base.  
Without protruding flange.
- Greater protection**  
against leakage, with the pump casing cover separated from the motor shield.  
Possibility of inspecting the seal through the side apertures between the two walls.  
Greater protection against water entering the motor from outside provided by an extension of the pump casing around the lantern bracket.