

# T, TP

## Peripheral Pumps



### Construction

Close-coupled peripheral pumps (regenerative pumps) with turbine impeller.

T, TP: version with pump casing and lantern bracket in cast iron.  
B-T, B-TP: version with pump casing and lantern bracket in bronze (the pumps are supplied fully painted).

### Applications

For clean liquids without abrasives, without suspended solids, non-explosive, non-aggressive for the pump materials.  
For increasing network pressure (follow local specifications).  
For the reduced dimensions, these pumps are very well suitable to be mounted in cooling and air-conditioning machines and equipments, circulation, boiler feed.

### Operating conditions

Liquid temperature from -10 °C to +90 °C.  
Ambient temperature up to 40 °C.  
Total suction lift up to 7 m.  
Continuous duty.

### Motor

2-pole induction motor, 50 Hz (n ≈ 2900 rpm).

**T, TP:** three-phase 230/400 V ± 10% up to 3 kW;  
400/690 V ± 10% from 4 to 7,5 kW;

**TM, TPM:** single-phase 230 V ± 10% with thermal protector.  
Capacitor inside the terminal box.

Insulation class F.

Protection IP 54.

**Classification scheme IE3 for three-phase motors from 0,75 kW.**

Constructed in accordance with: EN 60034-1; EN 60034-30-1.  
EN 60335-1, EN 60335-2-41.

### Special features on request

- Other voltages.
- Frequency 60 Hz (as per 60 Hz data sheet).
- Protection IP 55.
- Special mechanical seal.
- Higher or lower liquid or ambient temperatures.
- Construction with bearing bracket.

### Materials

Components	T, TP	B-T, B-TP
Pump casing	Cast iron	Bronze
Lantern bracket	GJL 200 EN 1561	G-Cu Sn 10 EN 1982
Casing cover	Cast iron	Bronze
	GJL 200 EN 1561	G-Cu Sn 10 EN 1982
	Brass P- Cu Zn Pb 40 2 UNI 5705 for T 61-65-70, B-T 61-70	
Impeller	Brass P- Cu Zn 40 Pb 2 UNI 5705	
	Bronze G-Cu Sn 10 EN 1982 for T 125, TP 132-132R	
Shaft	Cr-Ni steel AISI 303 T 76, Tp 80-100	Cr-Ni-Mo steel AISI 316
	Chrome steel AISI 430 T 61-65-70-100-125, Tp 78-132-132R	
Mechanical seal	Carbon - Ceramic - NBR	

### Coverage chart n ≈ 2900 rpm

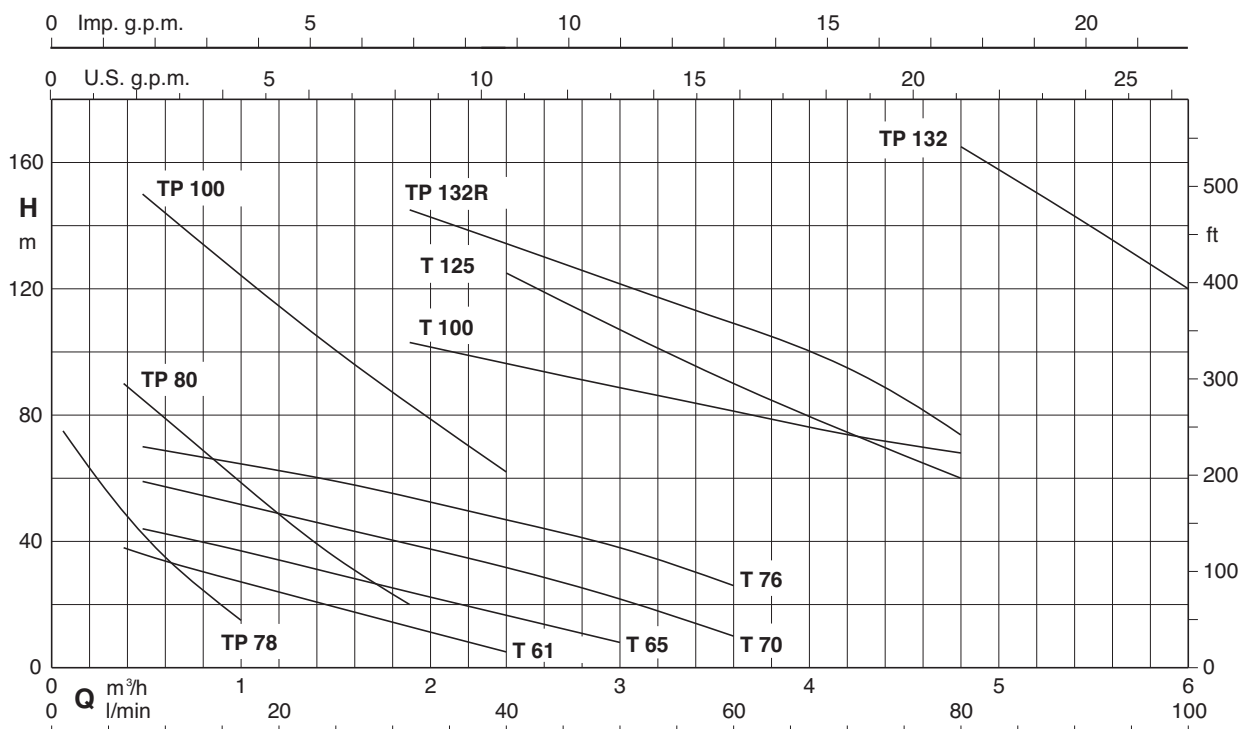

# T, TP

## Peripheral Pumps

### Performance $n \approx 2900$ rpm

3 ~	230V 400V		1 ~	230V		P <sub>1</sub>		P <sub>2</sub>		Q m <sup>3</sup> /h l/min	H																	
	A	A		A	kW	kW	HP	m	0,06		0,12	0,24	0,38	0,48	0,6	0,75	1	1,2	1,5	1,89	2,4	3	3,6	4,2	4,8	5,4	6	
B-T 61E	1,9	1,1	B-TM 61E	2,5	0,55	0,33	0,45			1	2	4	6,3	8	10	12,5	16	20	25	31,5	40	50	60	70	80	90	100	
B-T 65E	2,8	1,6	B-TM 65E	3,5	0,8	0,45	0,6						38	36	34	31,5	28	24	19	12,5	5							
B-T 70/B	3,7	2,2	B-TM 70/A	6	1,3	0,75	1						44	42	40	37	33	29	24	16	8							
T 76/A	5,3	3	TM 76E	7,4	1,6	1,1	1,5						59	57	55	51	48	43	38	30	22	10						
T 100/A	11,5	6,6				3	4						70	68	67	65	62	58	53	46	38	26						
T 125/B		9,6				4	5,5												103	97	89	82	75	68				
B-TP 78/A	2,3	1,3	B-TPM 78/A	2,8	0,6	0,37	0,5			75	70	60	50	42	35	25	15			125	110	90	75*	60*				
B-TP 80E	4	2,3	B-TPM 80E	5,8	1,2	0,75	1						90	85	79	73	61	48	34	20								
TP 100/B	9,6	5,5				2,2	3						150	144	136	125	115	100	84	62								
TP 132R/A		10,9				5,5	7,5												145	135	120	110	95	70				
TP 132/A		14,3				7,5	10																		165	143*	120*	

P1 Maximum power input.

B-T, B-TM = Bronze construction.

H Total head in m.

\* Maximum suction lift 2-3 m.

P2 Rated motor power output.

### Dimensions and weights

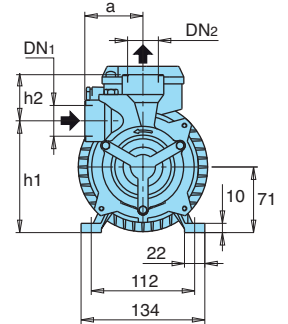
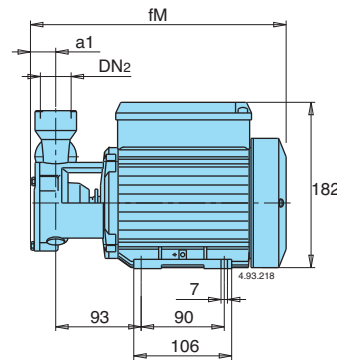
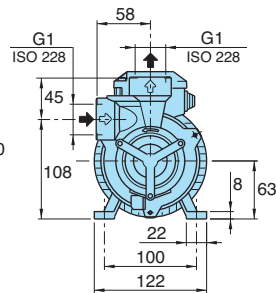
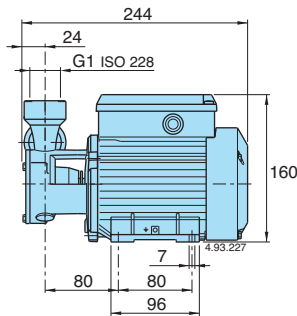

- T 61E: kg 6,3
- B-T 61E: kg 6,5
- T 65E: kg 7,3
- B-T 65E: kg 7,5

TYPE	DN1	DN2	mm					kg	
			ISO 228	a1	fM	h2	h1	a	T
T 70/B B-T 70/B	G 1	G 1	24	278	50	121	63	12	12,4
TP 78/A B-TP 78/A	G 1/2	G 1/2	22	276	24	127	56	8,2	8,8

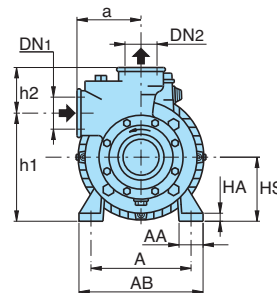
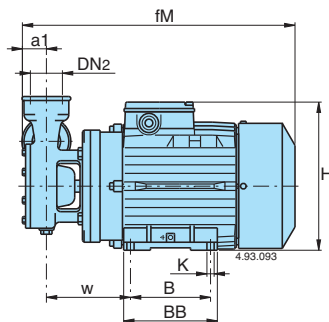

TYPE	DN1	DN2	mm														kg			
			ISO 228	a1	fM	HS	h2	h1	H	BB	B	AB	A	AA	K	a	w	HA	T, TP	B-TP
T 76/A	-	G 1 1/4	G 1 1/4	26	338	80	56	136	208	117	100	155	125	30	9	80	105	10	18,4	-
T 100/A	-	G 1 1/4	G 1 1/4	32	410	90	59	161	226	152	125	180	140	40	9,5	95	121	12	32,5	-
T 125/B	-	G 1 1/4	G 1 1/4	32	470	90	75	170	226	152	125	180	140	40	9,5	90	195	12	39,5	-
TP 80E B-TP 80E	-	G 3/4	G 3/4	27	332	80	35	135	208	117	100	155	125	30	9	60	104	10	16,4	16,8
TP 100/B	-	G 3/4	G 3/4	27	387	80	38	142	208	117	100	155	125	30	9	65	113	10	23,2	-
TP 132R/A	-	G 1 1/4	G 1 1/4	42	485	112	70	202	272	180	140	230	190	50	11,5	100	183	14	53,6	-
TP 132/A	-	G 1 1/4	G 1 1/4	42	485	112	70	202	272	180	140	230	190	50	11,5	100	183	14	58,5	-

# T, TP

## Peripheral Pumps

Raydar AB



### Characteristic curves $n \approx 2900$ rpm

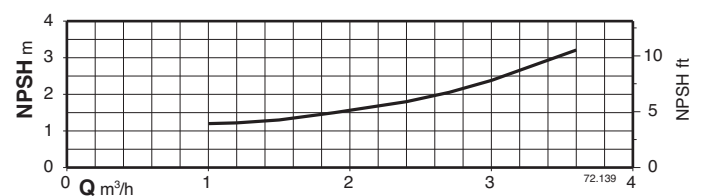
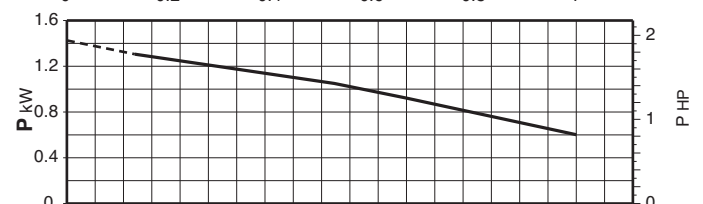
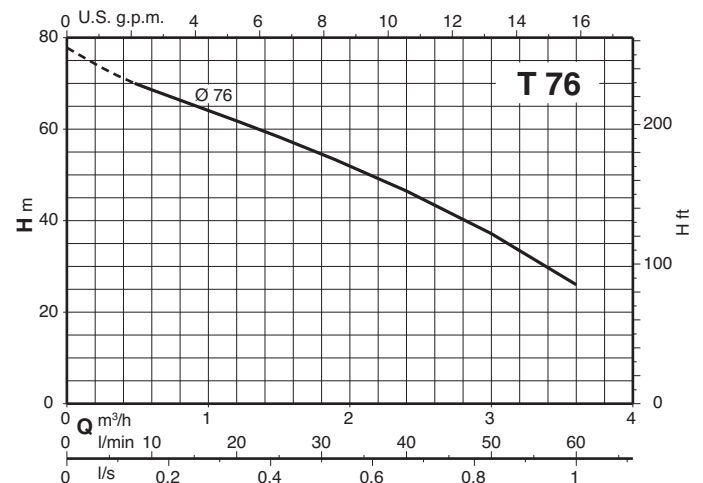
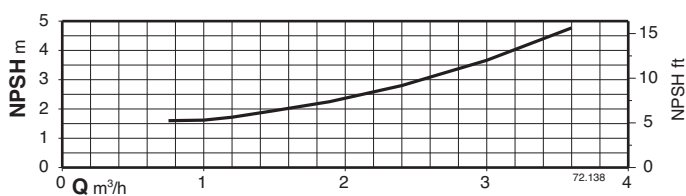
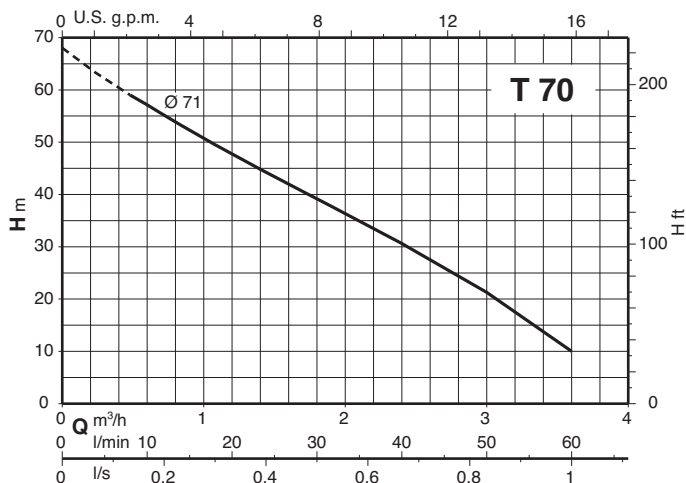
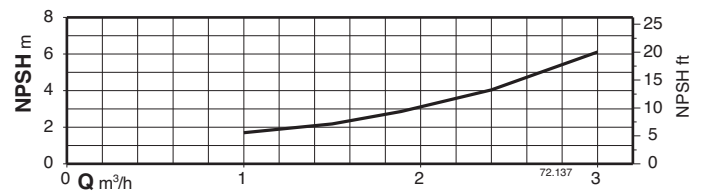
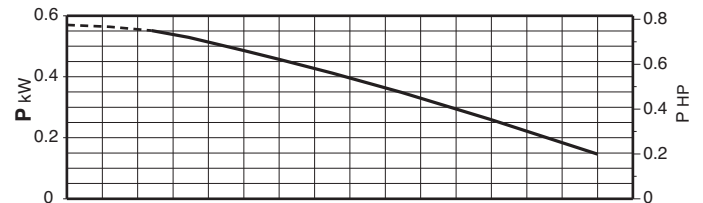
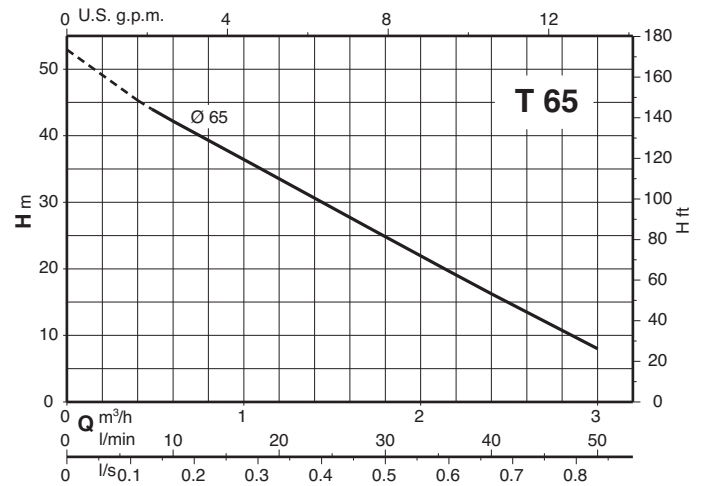
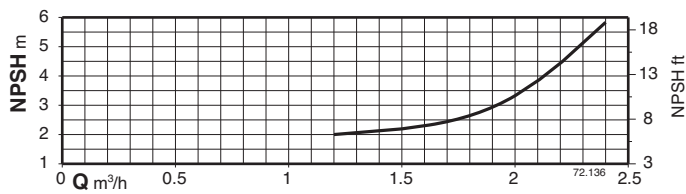
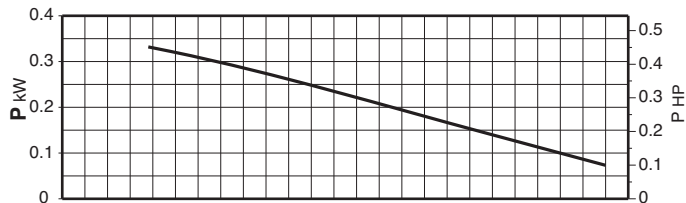
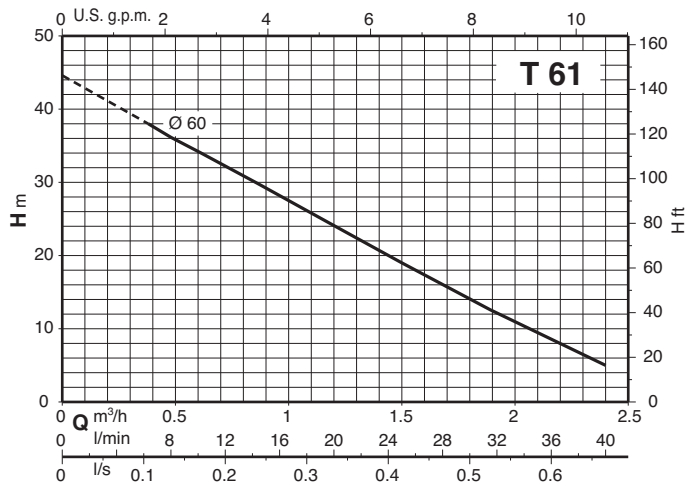

# T, TP

## Peripheral Pumps

### Characteristic curves $n \approx 2900$ rpm

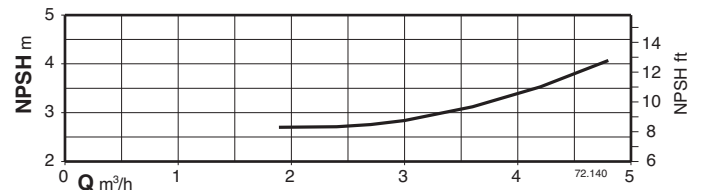
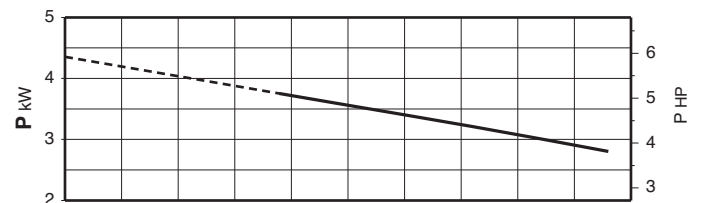
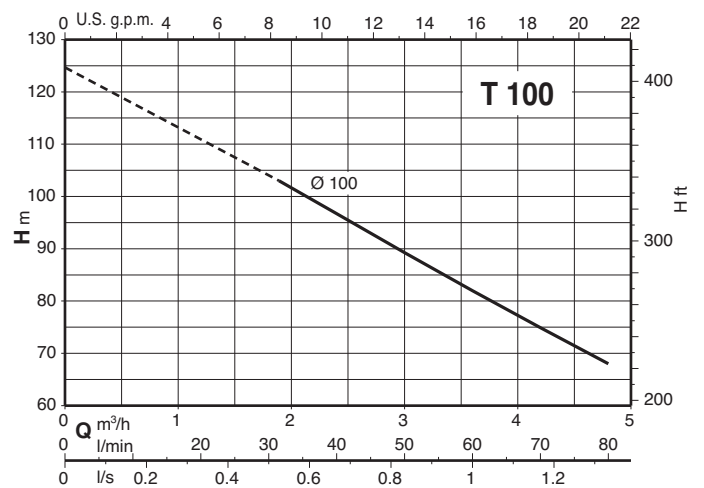
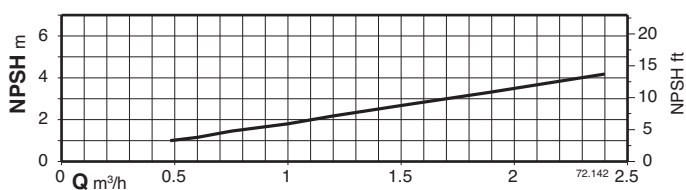
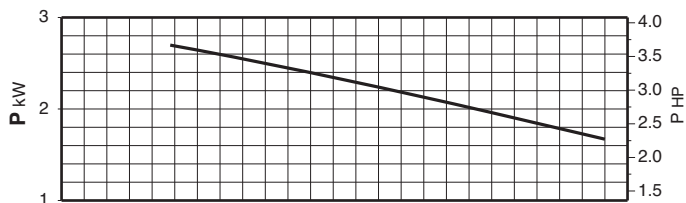
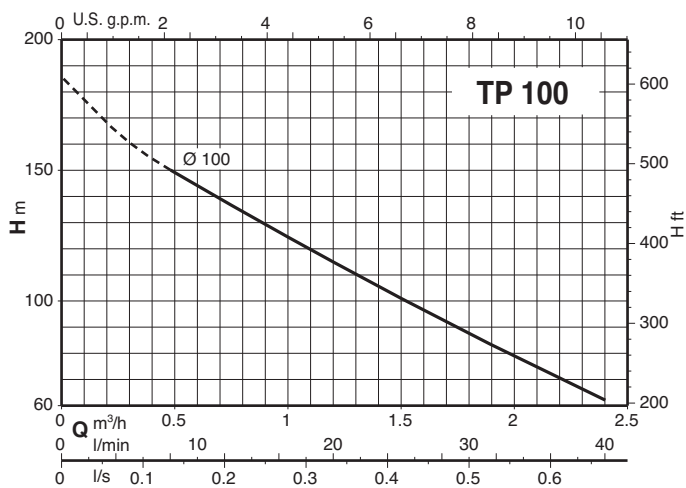
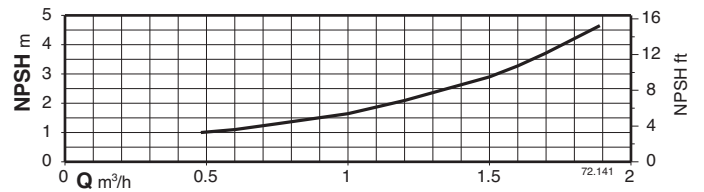
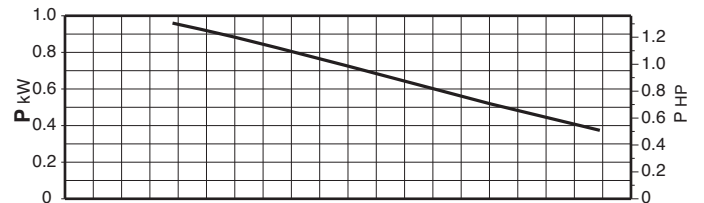
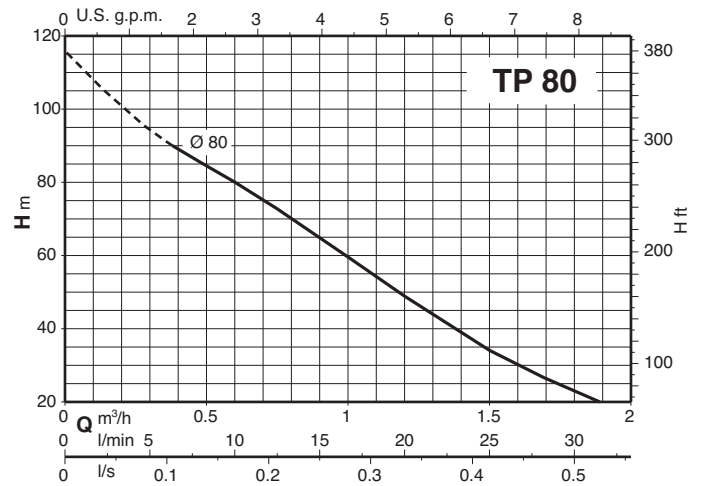
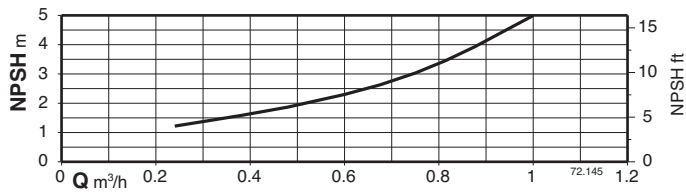
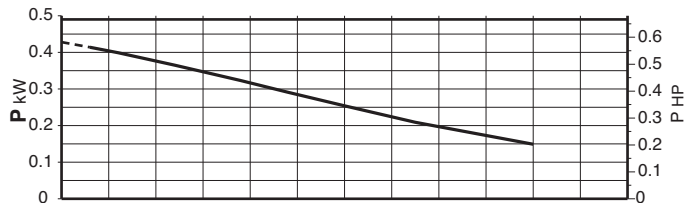
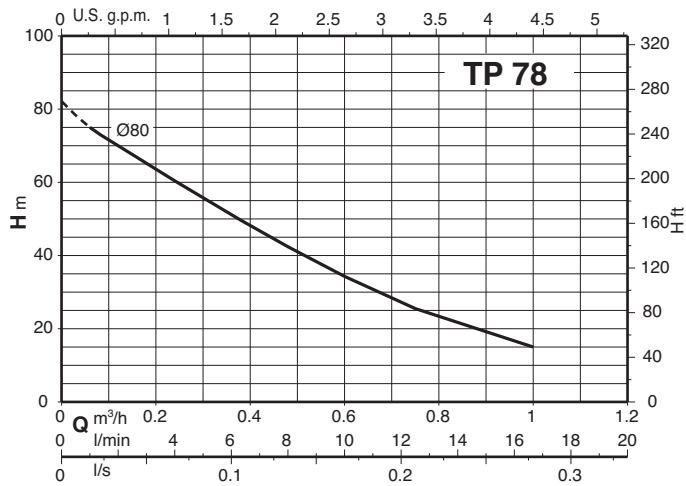

**Characteristic curves  $n \approx 2900$  rpm**

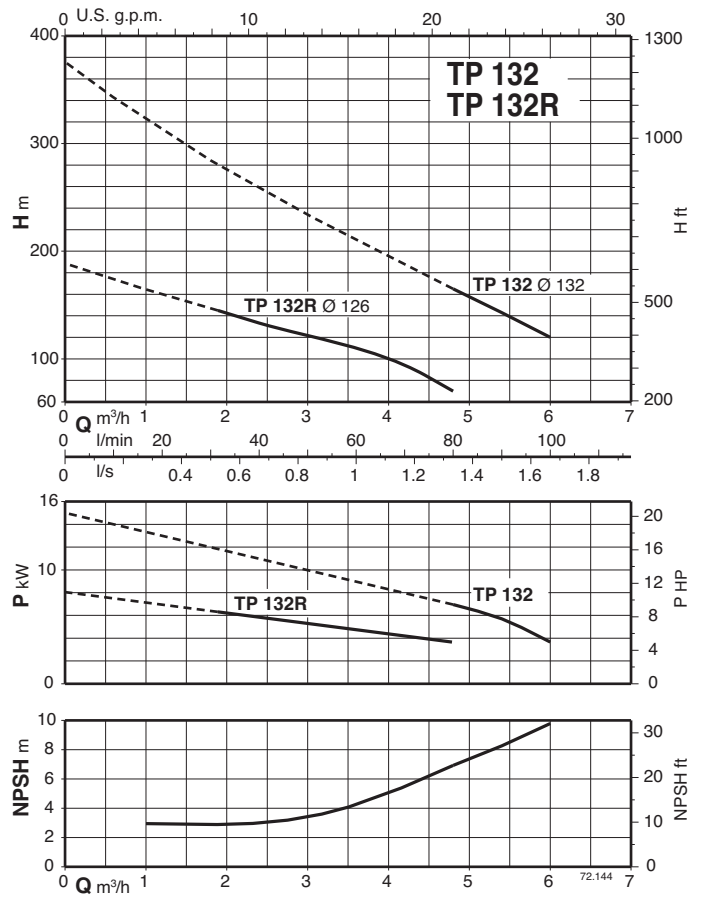
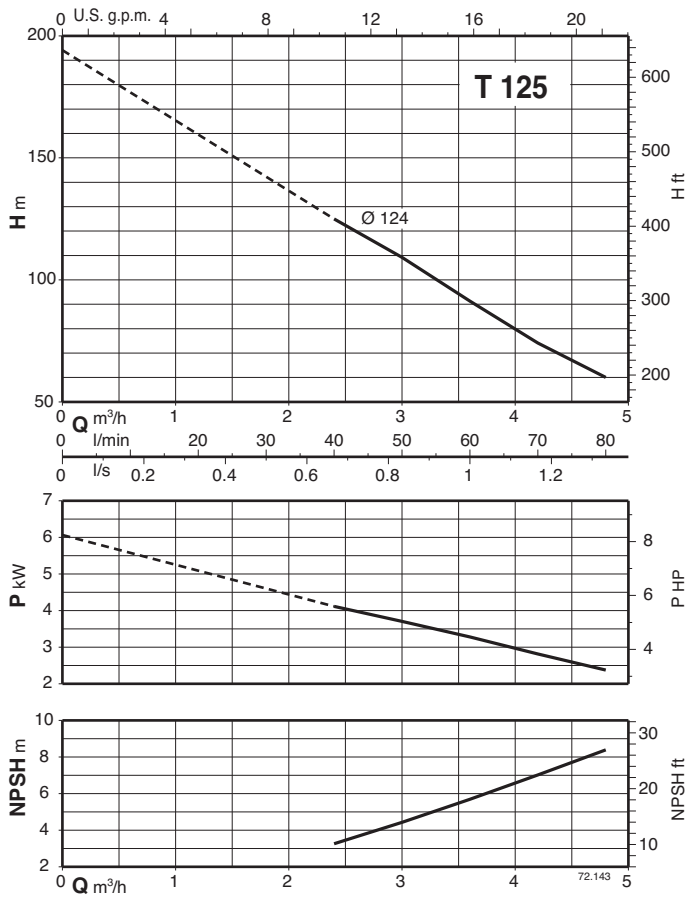

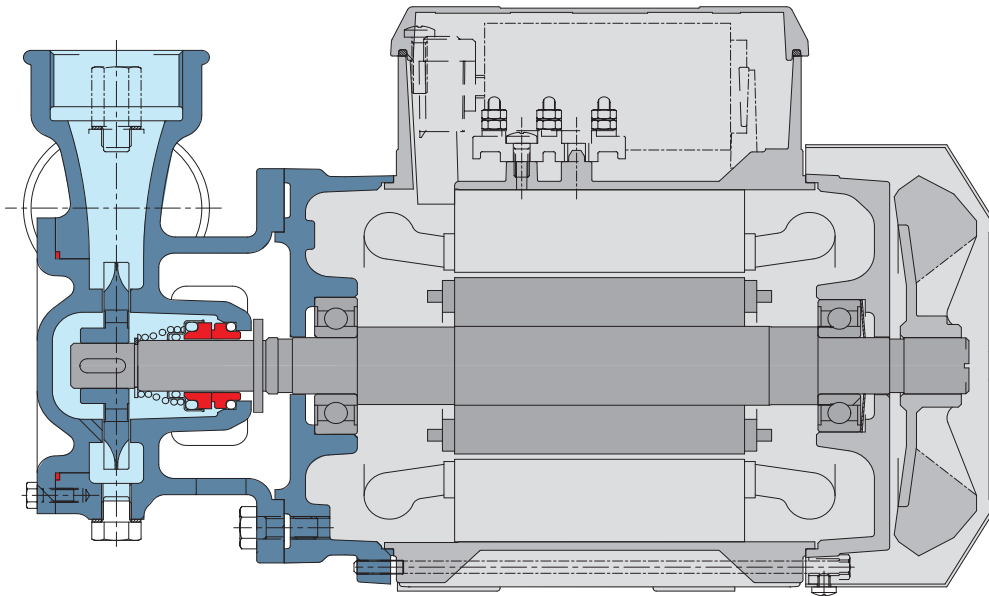
**Features****Range**

The high number of pumps in the range can meet the widest range of services required by the user.

**Flexible**

The option to choose between cast iron and bronze materials for the hydraulic parts in contact with the pumped liquid allows T-TP series pumps to be selected for use with different types of liquids.

**Reliable**

The bearing and shaft are designed to ensure the reduction of the stress, providing high reliability under all operating conditions.

**Optimized hydraulics**

The pump hydraulics are designed to ensure high performance and consistency of performance.