

# A

## Self-Priming Centrifugal Pumps with open impeller

Raydar AB



### Construction

Close-coupled centrifugal pumps with open impeller. The built-in backflow preventer avoids reverse siphoning when the pump is stopped and assures automatic re-priming at the next start. The pump re-priming itself even if partially filled with liquid and with completely empty suction pipe.  
 A: version with pump casing and lantern bracket in cast iron.  
 B-A: version with pump casing and lantern bracket in bronze (the pumps are supplied fully painted).

### Applications

For clean or slightly dirty water, also with solids up to 10 mm grain size for A 40, A 50 and 15 mm for A 65, A 80. For draining a basin or a sump. For irrigation. For civil and industrial applications.

### Operating conditions

Liquid temperature from -10 °C to +90 °C. Room temperature up to 40 °C. Maximum permissible working pressure up to 6 bar (10 bar for A 80-170). Continuous duty.

### Motor

2-pole induction motor, 50 Hz ( $n \approx 2900$  rpm).  
**A** three-phase 230/400 V  $\pm 10\%$  up to 3 kW; 400/690 V  $\pm 10\%$  from 4 to 7,5 kW;  
**AM**: single-phase 230 V  $\pm 10\%$ , with thermal protector. Capacitor inside the terminal box.

Insulation class F. Protection IP 54. **Classification scheme IE3 for three-phase motors from 0,75 kW.** Constructed in accordance with: EN 60034-1; EN 60034-30-1. EN 60335-1, EN 60335-2-41.

### Special features on request

Other voltages. Frequency 60 Hz (as per 60 Hz data sheet). Protection IP 55. Special mechanical seal. Higher or lower liquid or ambient temperatures. Construction with bearing bracket.

### Materials

Components	A	B-A
Pump casing Suction flange Inspection cover (for A 65, A 80) Lantern bracket Impeller	Cast iron GJL 200 EN 1561	Bronze G-Cu Sn 10 EN 1982
Shaft	Chrome-nickel steel 1.4305 EN 10088 (AISI 303) Chrome steel 1.4104 EN 10088 (AISI 430) for A 40/110, A 65-150A,B	Cr-Ni-Mo steel 1.4401 EN 10088 (AISI 316)
Mechanical seal	Carbon - Ceramic - NBR	

### Coverage chart $n \approx 2900$ rpm

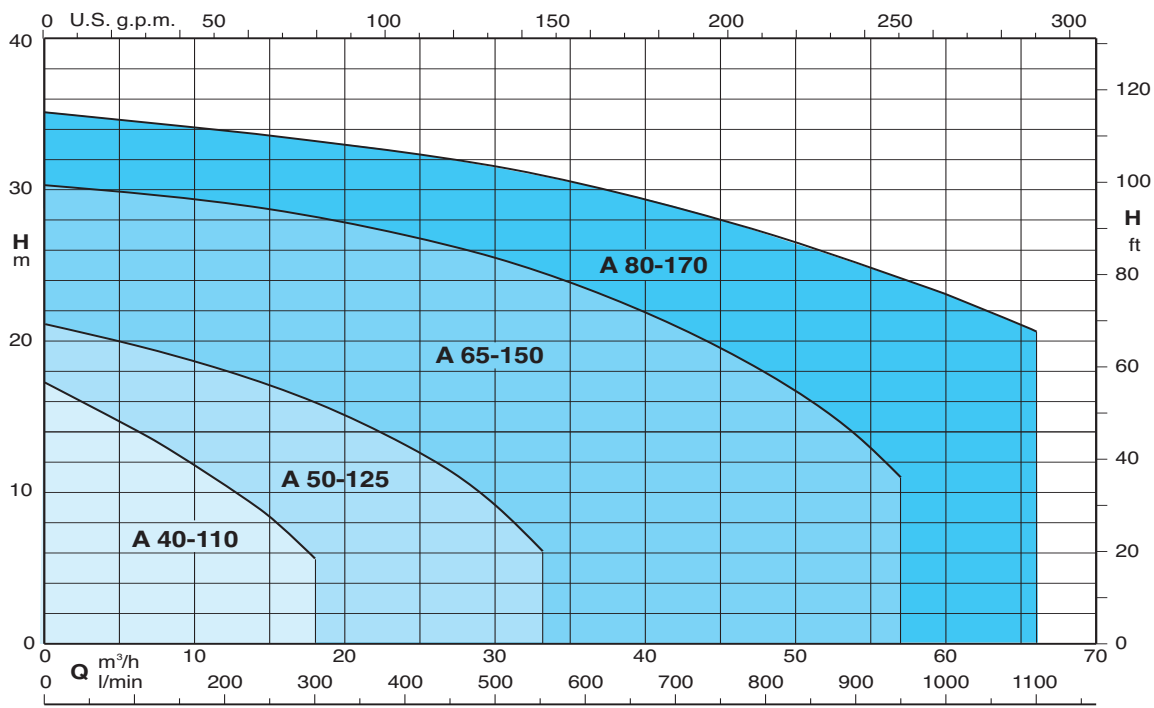



**Self-Priming Centrifugal Pumps**  
with open impeller

**Performance n ≈ 2900 rpm**

3 ~	230 V 400 V		1 ~	230 V		P <sub>1</sub>		P <sub>2</sub>		Q										
	A	A		A	kW	kW	HP	m <sup>3</sup> /h	3,6		4,8	6	7,5	8,4	9,6	10,8	12	15	18	
A 40-110B/A B-A 40-110B/A	2,8	1,6	AM 40-110B/A B-AM 40-110B/A	4,5	0,85	0,55	0,75	H m	12,9	12,4	11,8	11	10,4	9,8	9	8,3	6	3,4		
A 40-110A/B B-A 40-110A/B	3,7	2,2	AM 40-110A/A B-AM 40-110A/A	6	1,1	0,75	1		15,4	14,9	14,2	13,3	12,9	12,1	11,3	10,5	8,4	5,6		

3 ~	230 V 400 V		1 ~	230 V		P <sub>1</sub>		P <sub>2</sub>		Q										
	A	A		A	kW	kW	HP	m <sup>3</sup> /h	6		9	12	15	18	21	24	27	30	33	
A 50-125CE B-A 50-125CE	3,3	1,9	AM 50-125CE B-AM 50-125CE	5,8	1,2	0,75	1	H m	12,8	12,2	11,3	10	8,5	7	5,3	3,3				
A 50-125B/A B-A 50-125B/A	4,7	2,7	AM 50-125BE B-AM 50-125BE	7,4	1,6	1,1	1,5		15,5	14,9	14,2	12,9	11,6	10	8,3	6,2	4			
A 50-125A/A B-A 50-125A/A	7,5	4,3	AM 50-125AE B-AM 50-125AE	9,2	2,1	1,5	2		19,5	19	18	17	15,5	14	12,5	10,5	8	5		

3 ~	230 V 400 V		P <sub>2</sub>		Q											
	A	A	kW	HP		m <sup>3</sup> /h	15	18	24	30	33	36	42	48	54	57
A 65-150C/C B-A 65-150C/B	11,5 9,15	6,6 5,3	2,2	3	H m	17,5	17	16	14	13	11,5	9	6,5			
A 65-150B/B B-A 65-150B/A	11,5	6,6				21,5	21	19,5	17,5	16,5	15,5	12,5	9,5	6,5		
A 65-150A/C B-A 65-150A/B	-	9,6				29	28	27	25,5	24,5	23,5	21	18	14	11	

3 ~	230 V 400 V		P <sub>2</sub>		Q										
	A	A	kW	HP		m <sup>3</sup> /h	15	18	21	24	30	36	45	54	60
A 80-170B/A B-A 80-170B/A	-	10,9	5,5	7,5	H m	27,3	27,3	27	26,8	25,7	24,4	22,1	19	16,7	13,7
A 80-170A/A B-A 80-170A/A	-	14,3				33,6	33,2	32,9	32,5	31,6	30,5	28,1	25,3	23,2	20,4

P<sub>1</sub>: Maximum power input. P<sub>2</sub>: Rated motor power output. H: Total head in m. B-A, B-AM = Bronze construction. Tolerances according to UNI EN ISO 9906:2012

# A Self-Priming Centrifugal Pumps with open impeller

## Self-priming capability

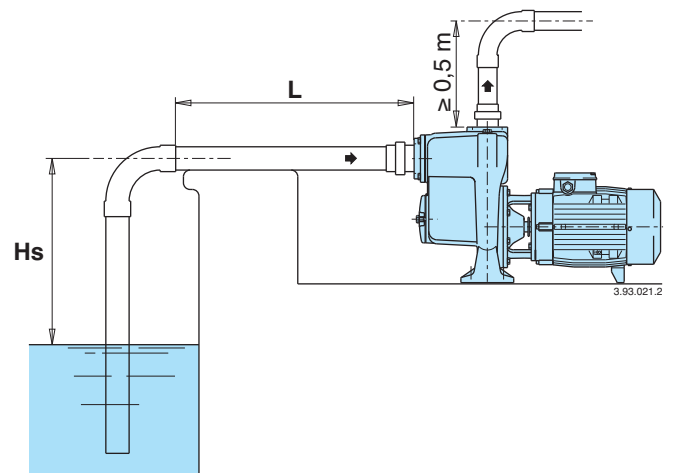
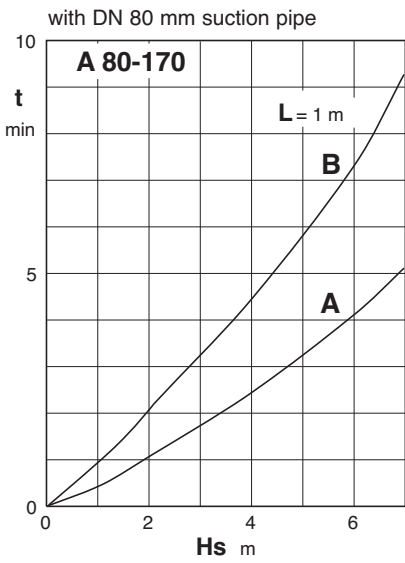
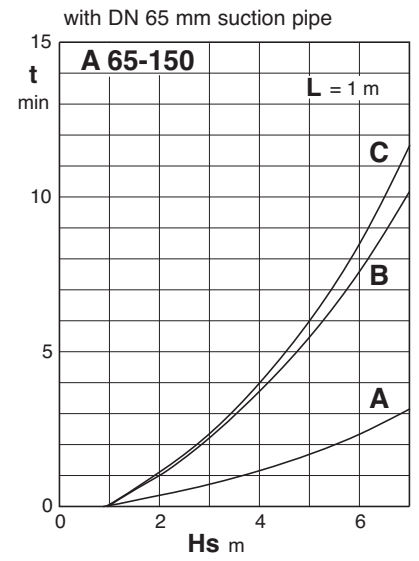
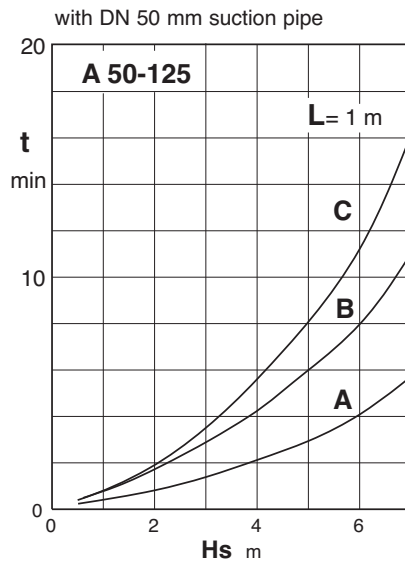
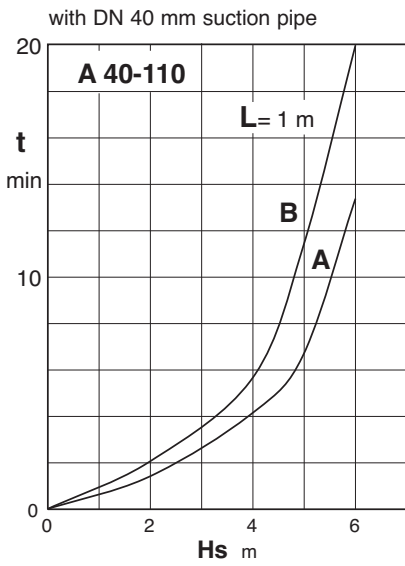



**Self-Priming Centrifugal Pumps  
with open impeller**

Raydar AB



**Characteristic curves  $n \approx 2900$  rpm**

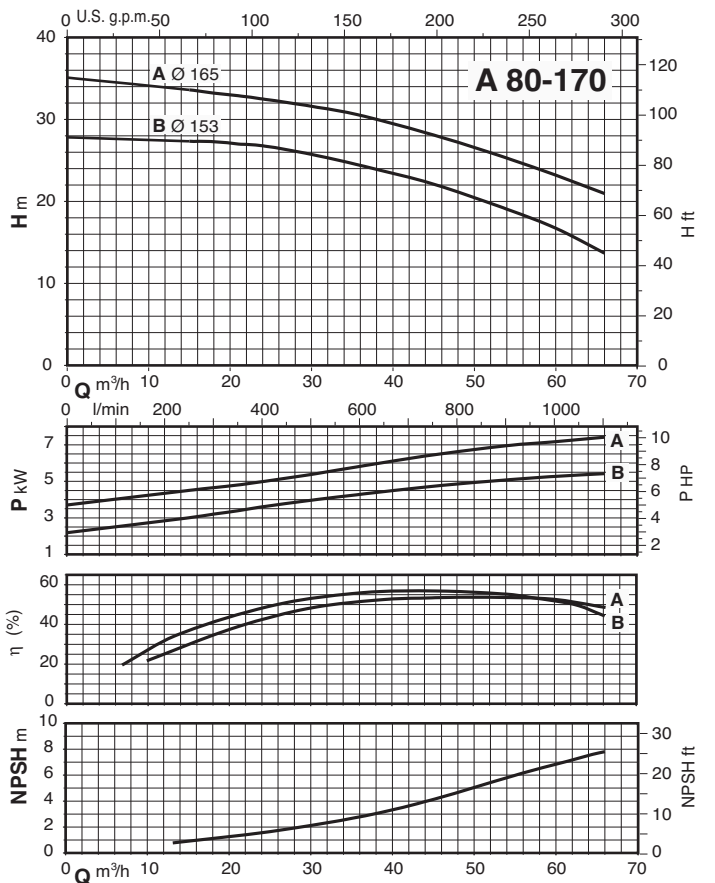
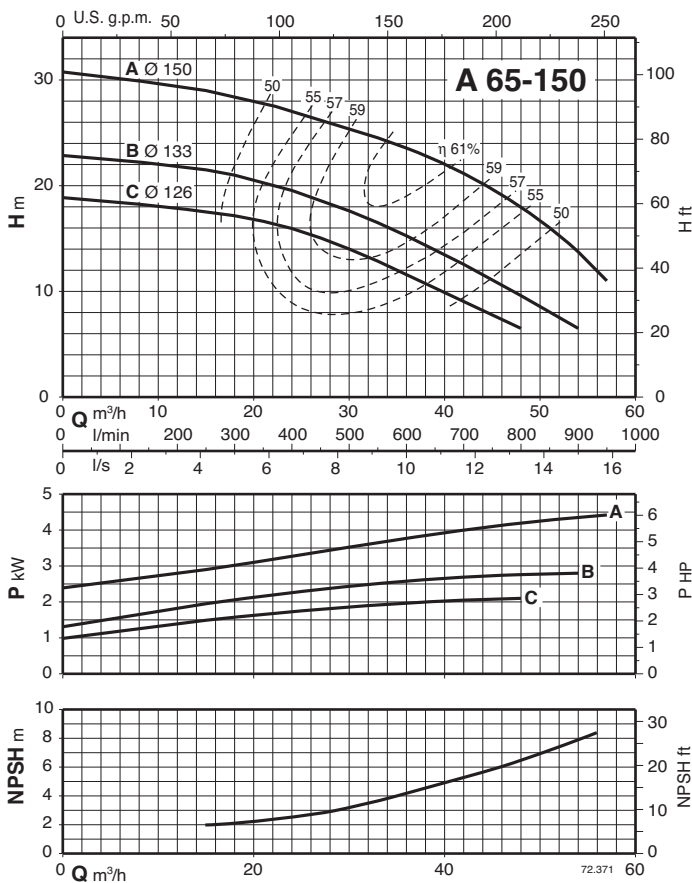
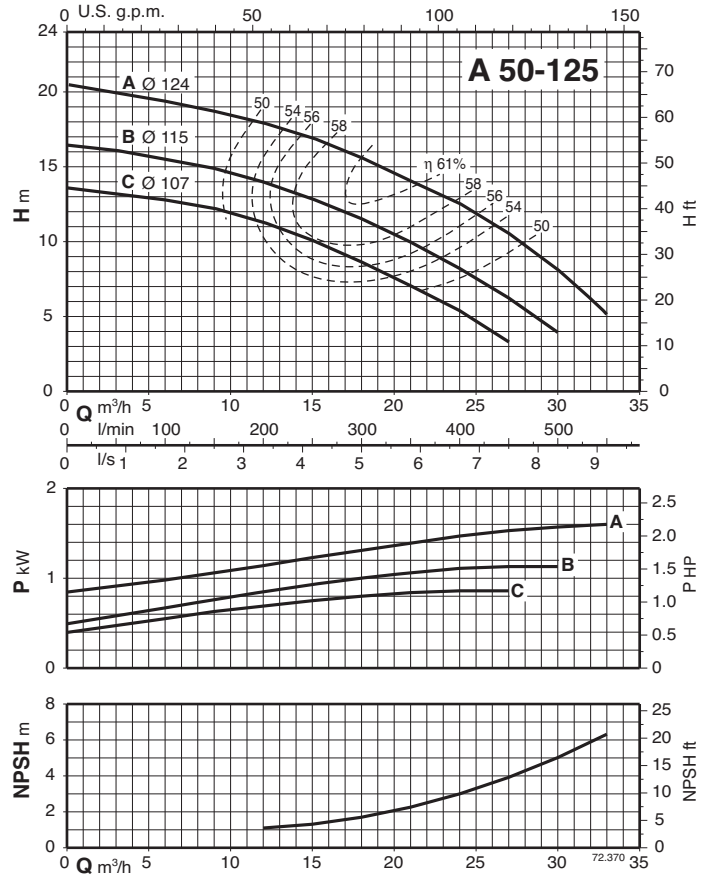
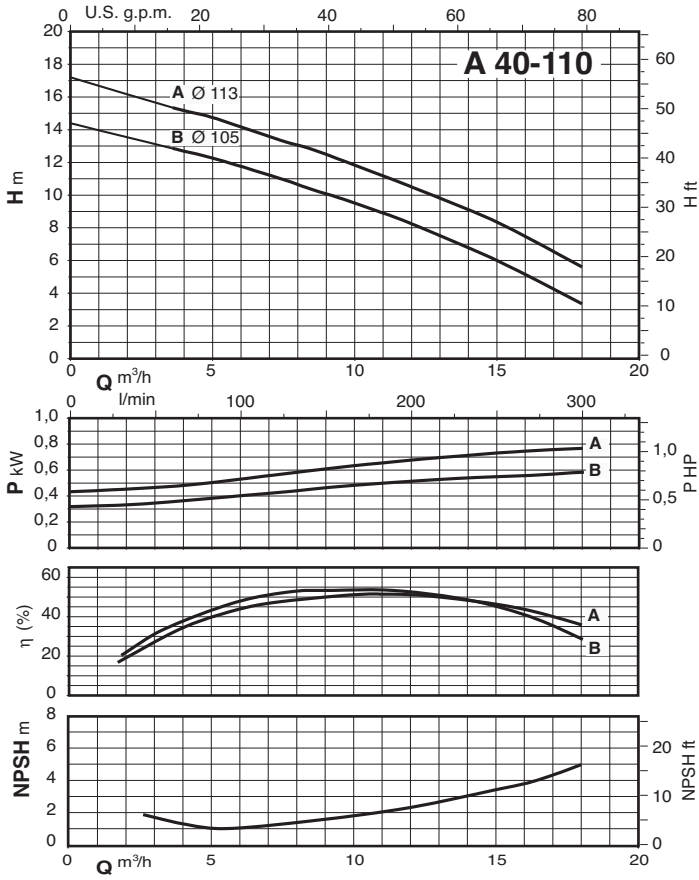

### Dimensions and weights

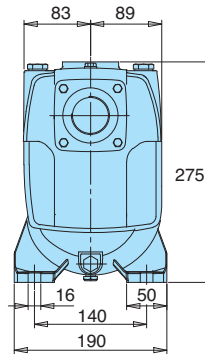
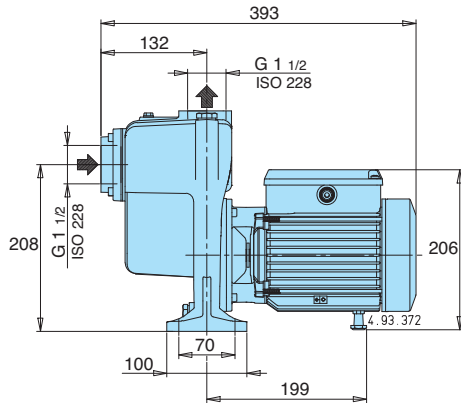

kg

A 40-110A/B	20,6
AM 40-110A/A	20,8
A 40-110B/A	18,9
AM 40-110B/A	19,8

B-A 40-110A/B	23,3
B-AM 40-110A/A	23,5
B-A 40-110B/A	21,6
B-AM 40-110B/A	22,5

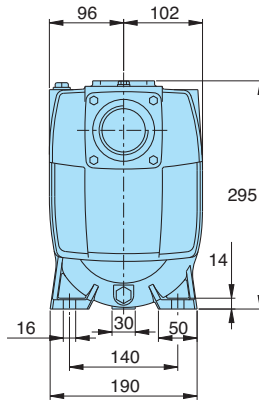
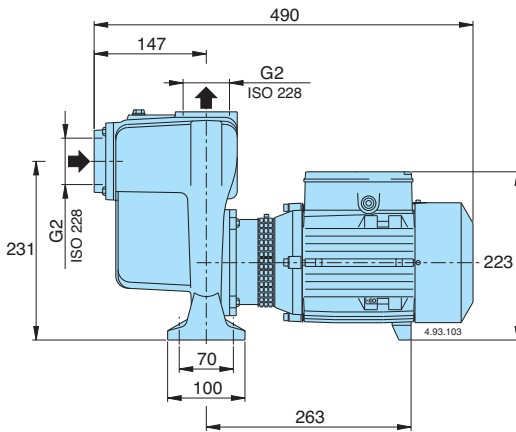

kg

A 50-125A/A	29,9
AM 50-125AE	31
A 50-125B/A	28
AM 50-125BE	29,1
A 50-125CE	26,9
AM 50-125CE	27,8

B-A 50-125A/A	33,6
B-AM 50-125AE	33,6
B-A 50-125B/A	31
B-AM 50-125BE	32,6
B-A 50-125CE	29,6
B-AM 50-125CE	30,6

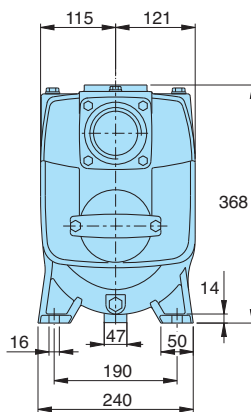
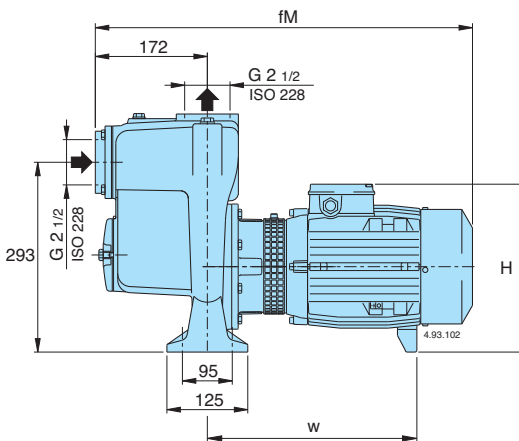

TYPE	mm			kg
	fM	H	w	
A 65-150C/C	595	270	324	56,7
B-A 65-150C/B	583	260	319	50,4
A 65-150B/B	595	270	324	57
B-A 65-150B/A	595	270	324	58,5
A 65-150A/C	595	270	324	58,5
B-A 65-150A/B	595	270	324	60

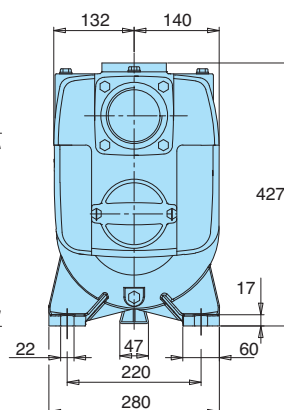
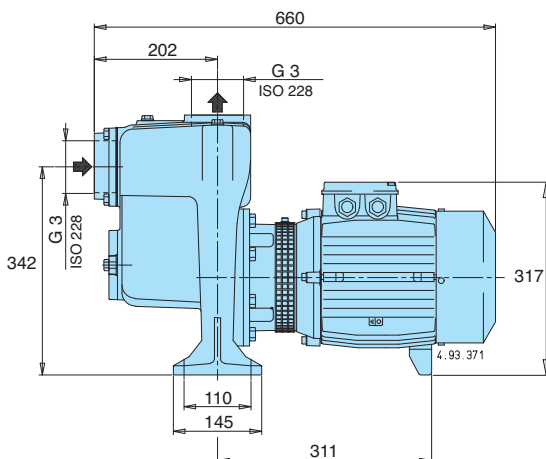

kg

A 80-170A/A	85,8
A 80-170B/A	80,3

B-A 80-170A/A	95,6
B-A 80-170B/A	90,1

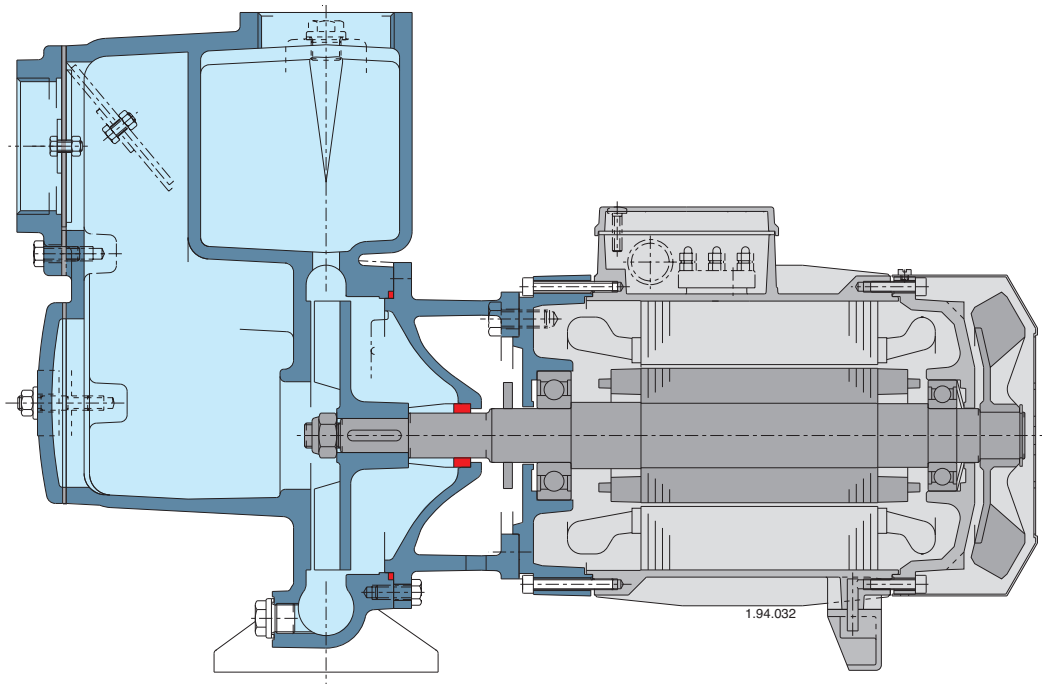
**Features****Fast self priming**

An integrated non-return valve and the design of the pump casing ensures rapid priming, once the pump body has been filled with water.

**Flexible**

The option to choose between cast iron and bronze materials for the hydraulic parts in contact with the pumped liquid allows A series pumps to be selected for use with different types of liquids.

**Solid parts**

The open impeller allows for the passage of suspended solids in pumped liquid.

**Exclusive design**

An innovative, patented guard prevents contact with rotating parts, proving protection to the end user whilst allowing for inspection of the mechanical seal.

**Reliable**

The bearing and shaft are designed to ensure the reduction of the stress, providing high reliability under all operating conditions.