

NC3

Three speeds circulating pumps with threaded ports



CANNOT BE SOLD IN THE EU

Construction

Pump casing with suction and delivery connections with the same diameter and on the same axis (in-line).
Brass or cast iron unions on request.

Component	Materials
Pump casing	Cast iron
Impeller	Composite
Shaft	Stainless steel AISI 420

Applications

For clean liquids, without abrasives, which are non-aggressive for the pump materials.
Civil and industrial heaty systems.

Operating conditions

Liquid temperature from +5 °C to +110 °C (from -10 °C to +110 °C for NC3 ..-70 and NC3 ..-80-85-120).
Ambient temperature up to 40 °C.
Sound pressure ≤ 43 dB (A).
Maximum glycol quantity: 50% (Mixture with more than 20% glycol content require rechecking of the pumping data).
Maximum permissible working pressure 10 bar.

TYPE	Minimum suction pressure: bar		
	Temperature		
	50 °C	80 °C	110 °C
NC3 ..-40,50,60	0,05	0,4	1,1
NC3 ..-70	0,05	0,4	1,1
NC3 ..-80,85,120	0,05	0,4	1,2

Motor

2-pole induction motor, 50 Hz.
Three adjustable speeds.
NC3: single-phase 230 V.
Insulation class H.
Protection IP 44.

Installation

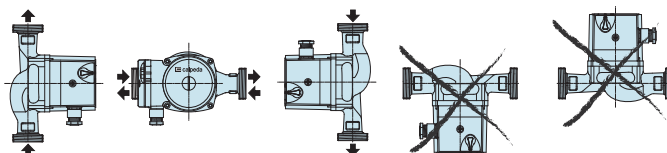

Unions

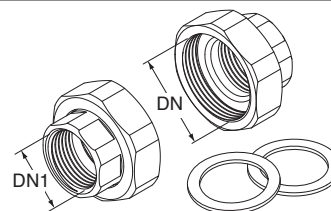

TYPE	DN	DN1
KIT G 1 - G 1/2 (NC3 15..)	G 1	G 1/2
KIT G 1 1/2 - G 1 (NC3 25..)	G 1 1/2	G 1
KIT G 2 - G 1 1/4 (NC3 32..)	G 2	G 1 1/4

Designation

Series _____ **NC3 32 - 70 / 180**
 DN ports in mm _____
 Max. head in dm _____
 connection size mm _____

NC3

Three speeds circulating pumps with threaded ports

Raydar AB



Characteristic curves, dimensions and weights

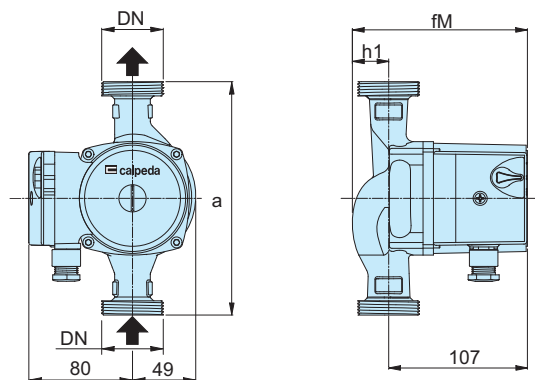
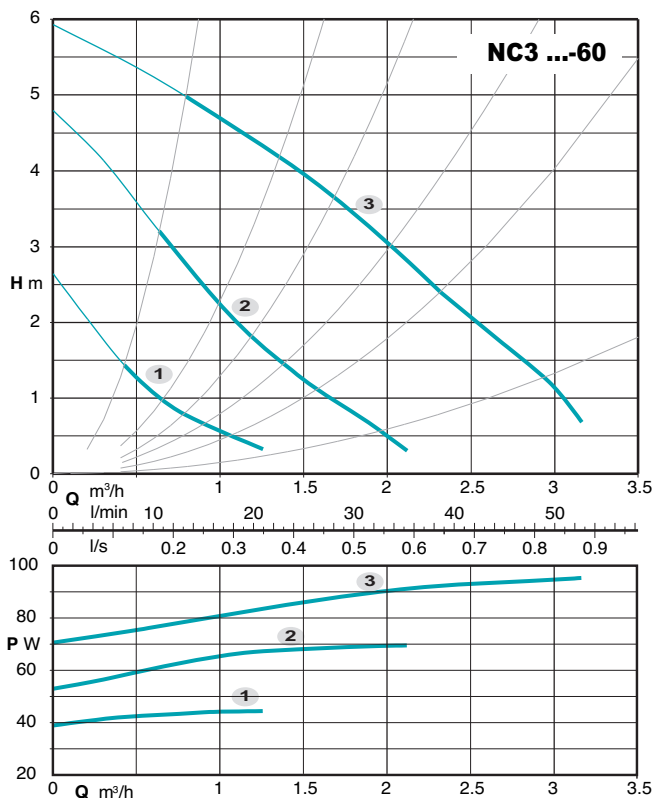
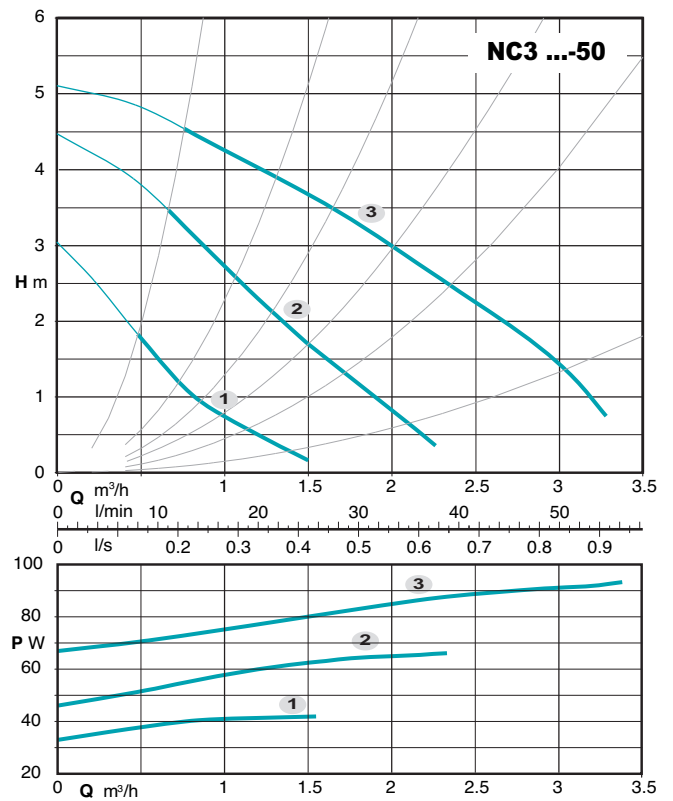
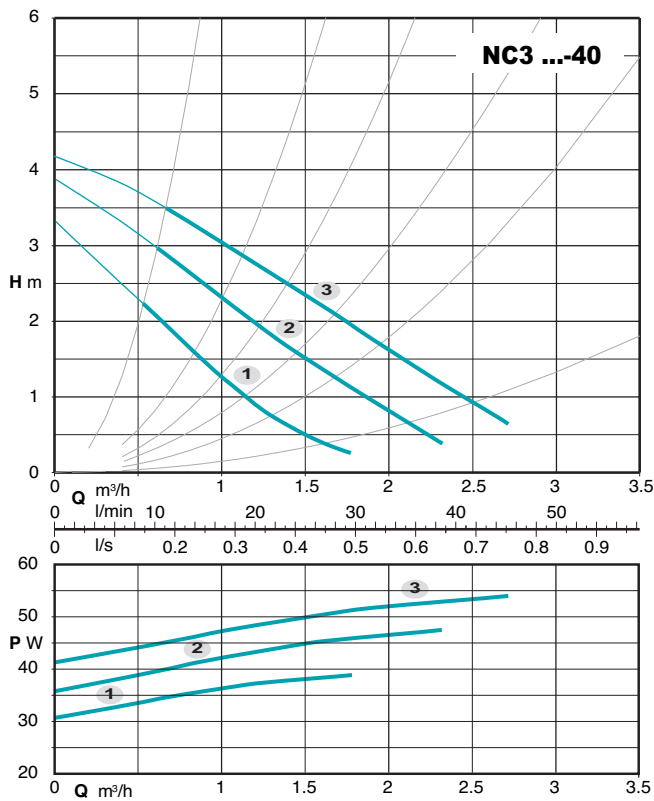

TYPE	DN	Pos.	P1 (W)	1x 230 V [A]	mm			[kg]
					a	fM	h1	
NC3 15-40/130	G 1	3	53	0,23	130	128	21	2,2
NC3 25-40/130	G 1 1/2	2	47	0,21	130	135	28	2,4
NC3 25-40/180	G 1 1/2	1	38	0,17	180	135	28	2,6
NC3 15-50/130	G 1	3	91	0,38	130	128	21	2,2
NC3 25-50/130	G 1 1/2	2	65	0,28	130	135	28	2,4
NC3 25-50/180	G 1 1/2	1	42	0,18	180	135	28	2,6
NC3 32-50/180	G 2	1			180	138	31	3
NC3 15-60/130	G 1	3	95	0,41	130	128	21	2,2
NC3 25-60/130	G 1 1/2	2	70	0,30	130	135	28	2,4
NC3 25-60/180	G 1 1/2	1			180	135	28	2,6
NC3 32-60/180	G 2	1	44	0,20	180	138	31	3

NC3 Three speeds circulating pumps with threaded ports

Characteristic curves, dimensions and weights

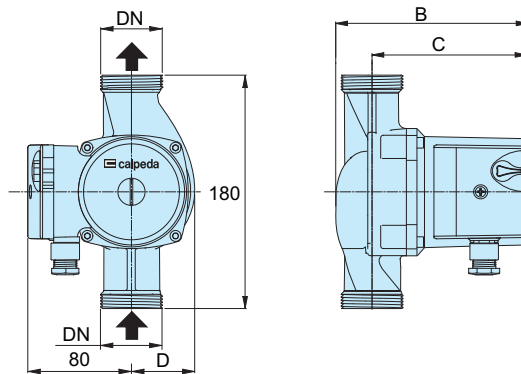
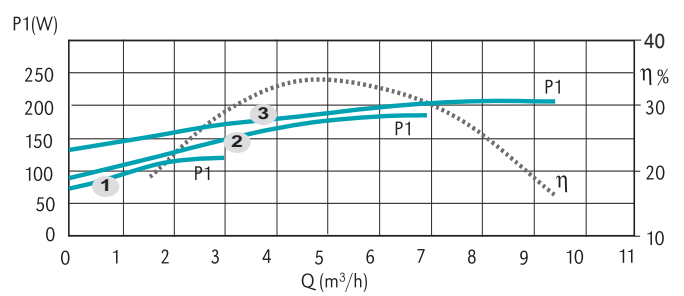
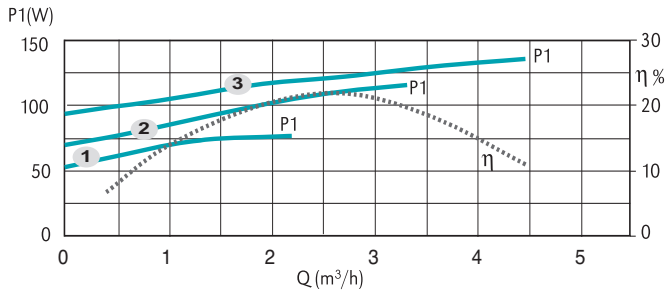
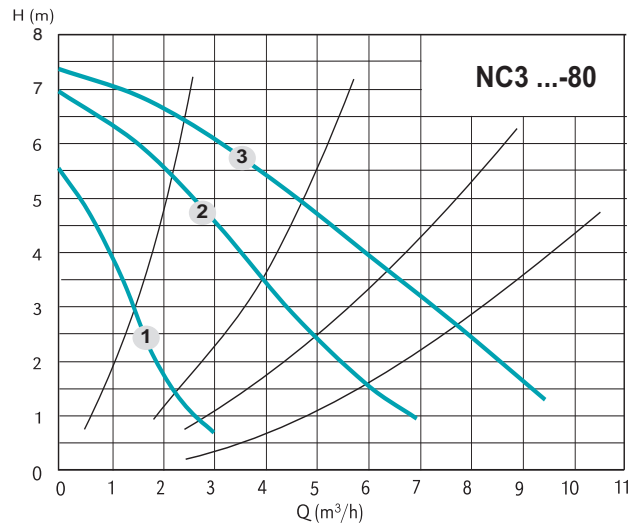
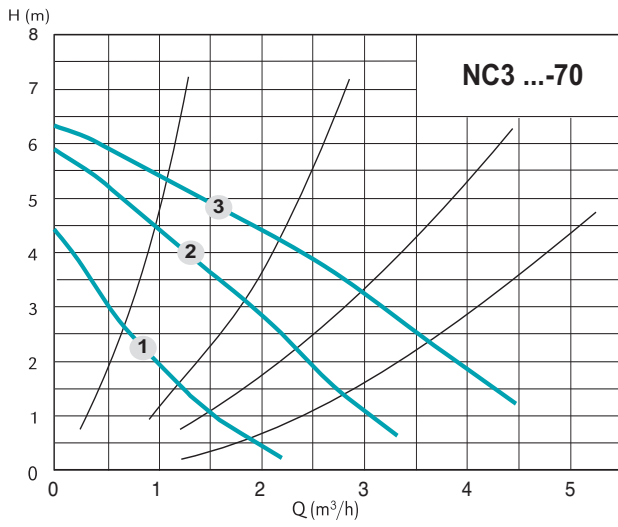

TYPE	DN	Pos.	P1 (W)	1x 230 V [A]	[mm]			[kg]
					B	C	D	
NC3 25-70/180	G 1 1/2	3	136	0,61	135	107	49	2,9
		2	116	0,54				
		1	77	0,37				
NC3 32-70/180	G 2	3	136	0,61	138	107	49	3,1
		2	116	0,54				
		1	77	0,37				
NC3 32-80/180	G 2	3	206	0,91	185	143	58	4,7
		2	185	0,88				
		1	120	0,60				

NC3 Three speeds circulating pumps with threaded ports

Characteristic curves, dimensions and weights

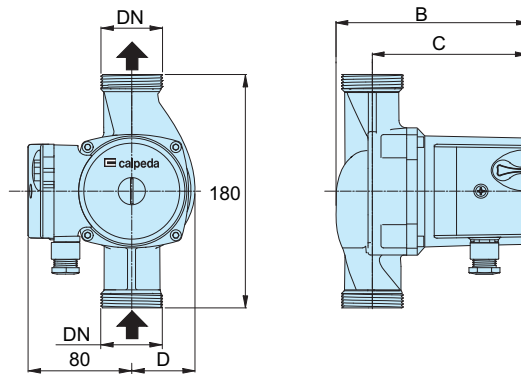
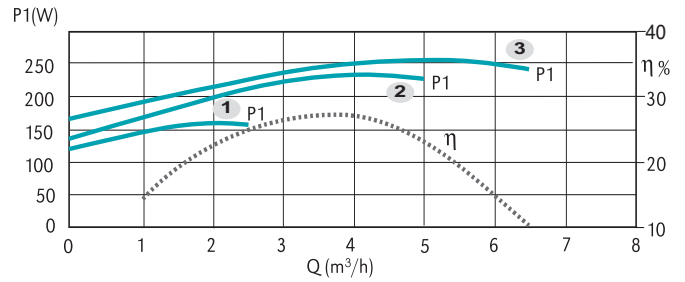
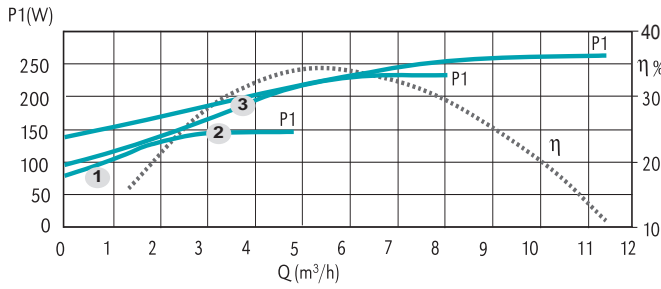
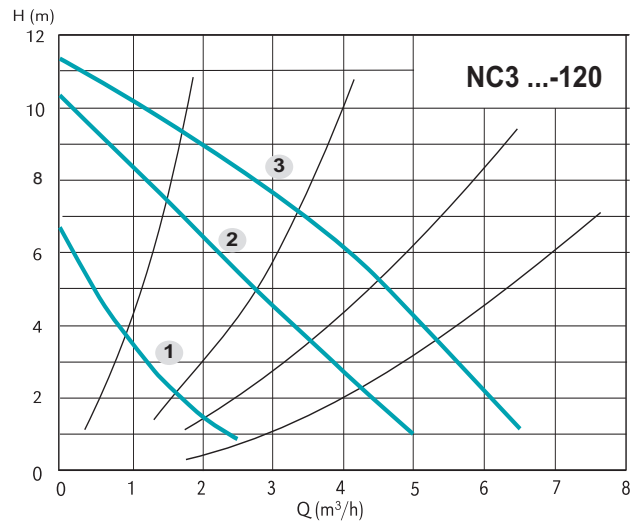
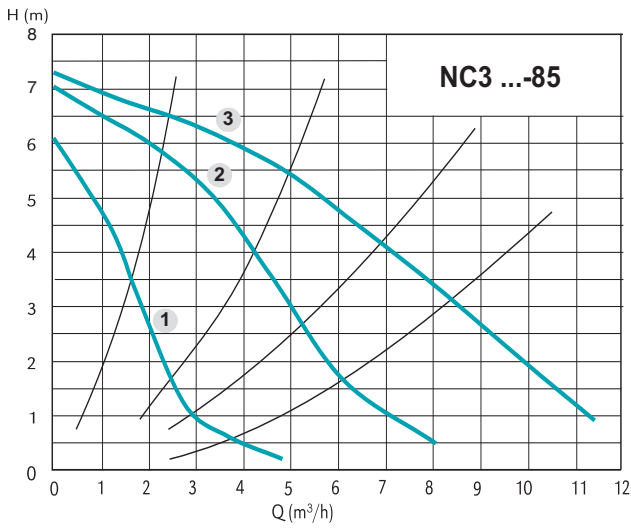

TYPE	DN	Pos.	P1 (W)	1x 230 V [A]	[mm]			[kg]
					B	C	D	
NC3 32-85/180	G 2	3	277	1,2	185	143	58	4,9
		2	250	1,16				
		1	172	0,85				
NC3 32-120/180	G 2	3	265	1,15	208	174	68	5,2
		2	251	1,14				
		1	176	0,85				